

# *Homeowner's Guide to* **OIL TANKS**





# TABLE OF CONTENTS

1. Introduction .....	2	5. Replacing Your Heating Oil Tank .....	18
1.1 Use of this Guide .....	5	5.1 Single-wall Steel Heating Oil Tank .....	18
2. Your Roles and Responsibilities .....	6	5.2 Epoxy-coated, Single-wall Steel Heating Oil Tank .....	18
3. Case Studies .....	7	5.3 Double-wall Steel Heating Oil Tank .....	18
3.1 Indoor Spill .....	7	5.4 Double-wall Steel and Polyethylene Heating Oil Tank .....	19
3.2 Outdoor Spill .....	7	5.5 Fibreglass Heating Oil Tank .....	20
4. What to Look For .....	8	5.6 Used/Second-hand Heating Oil Tanks .....	20
4.1 Certification Plates .....	8	5.7 Which Option Should You Choose? .....	20
4.2 Rusting/Corrosion/Dents/ Physical Damage .....	9	6. Other Considerations .....	21
4.3 Drip Leg .....	10	6.1 Thermal Expansion .....	21
4.4 Tank Stand .....	11	6.2 Transfer of Product .....	21
4.5 Flex Connectors .....	11	6.3 Tank Movement and Levelling .....	22
4.6 Fittings and Valves .....	12	6.4 Insurance Considerations .....	22
4.7 Fuel Lines .....	13	7. Spills .....	23
4.8 Fill and Vent Pipes, Caps and Vent Whistles .....	14	7.1 First Response .....	23
4.9 Drips and Ground Staining .....	15	7.2 Reporting Spills .....	24
4.10 Oil Level Gauge .....	16	8. Legislation, Codes and Standards .....	25
4.11 Secondary Containment .....	16	9. References .....	26
4.12 Tank Location .....	17	Appendix	
		NT-NU Spill Report Form .....	29
		Instructions .....	30

All photos courtesy of the Government of the Northwest Territories, unless otherwise stated.

# 1. INTRODUCTION

Large, unexpected bills can be a home and business owner's nightmare. An improperly installed and/or poorly maintained oil tank can leak or spill unexpectedly, often costing in the tens to hundreds of thousands of dollars and be harmful to people, your property and the environment. It is the legal and financial responsibility of the homeowner, commercial building owners and/or property managers to clean up all heating oil tank leaks and spills.



The Department of Environment and Natural Resources has developed this *Homeowner's Guide to Oil Tanks* to help prevent this unwelcome surprise.

This Guide is intended to:

- act as a pollution prevention measure;
- alert home, building and property owners about the potential environmental and financial liability of an oil spill; and
- provide some simple, practical steps that can minimize the chances of an oil spill.

All oil tanks and associated appliances, equipment, components and accessories, must be installed according to the adopted version of the National Fire Code of Canada. Beginning July 1, 2010, the new B139-09 Installation Code for Oil Burning Equipment comes into effect. The Office of the Fire Marshal is the authority having jurisdiction and has adopted these codes under the Fire Prevention Regulations. All outdoor steel residential tanks must be double-wall with interstitial monitoring (i.e. having a signal device to indicate a leak). Tanks installed before July 1, 2010 will fall under the 2004 code.

For more information, see Section 8. Legislation, Codes and Standards.

# Typical Indoor Tank Installations

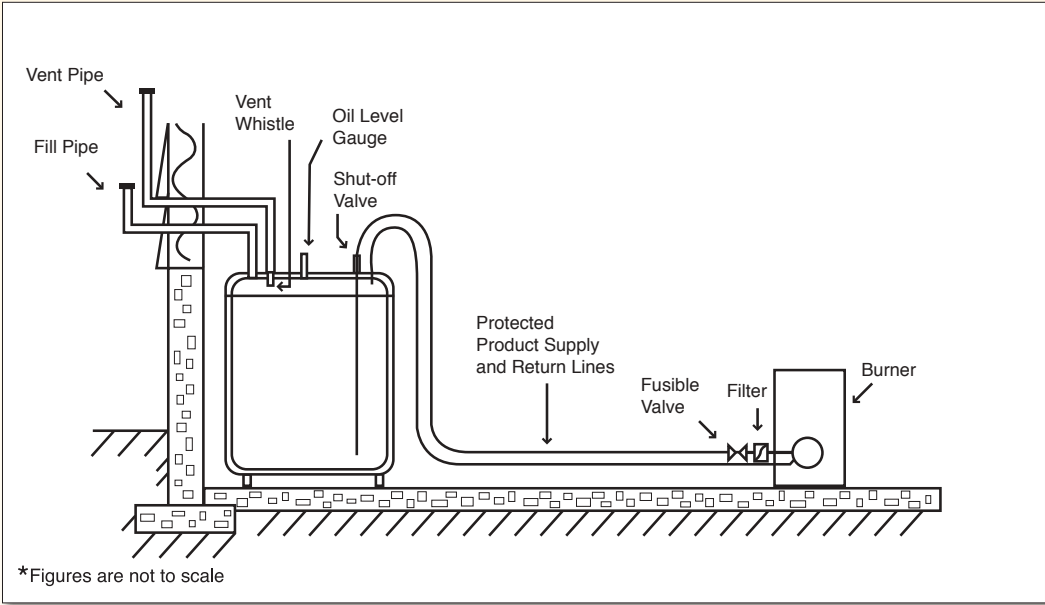
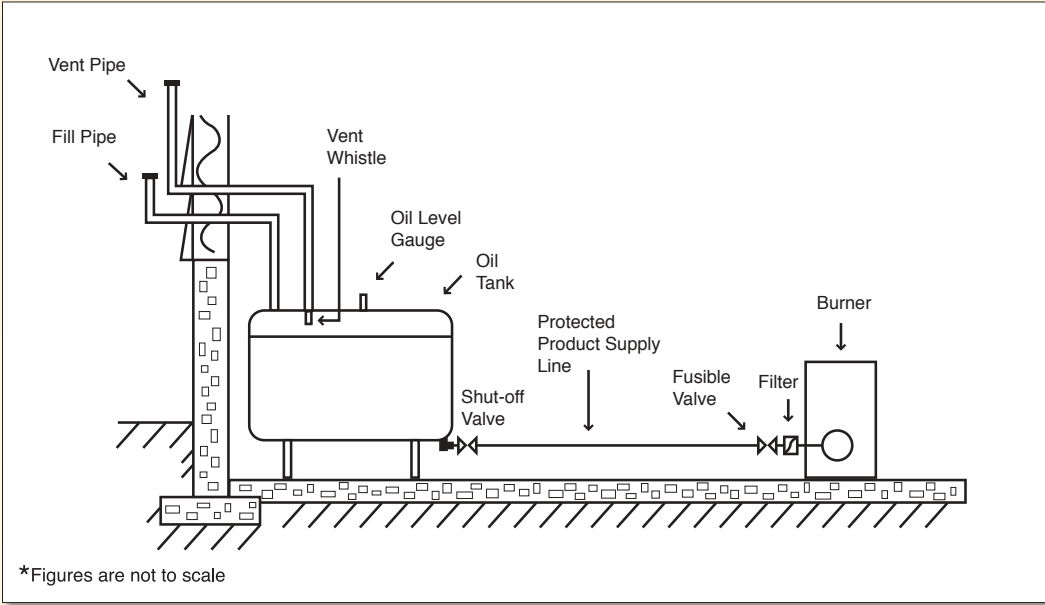

## Typical Outdoor Tank Installations

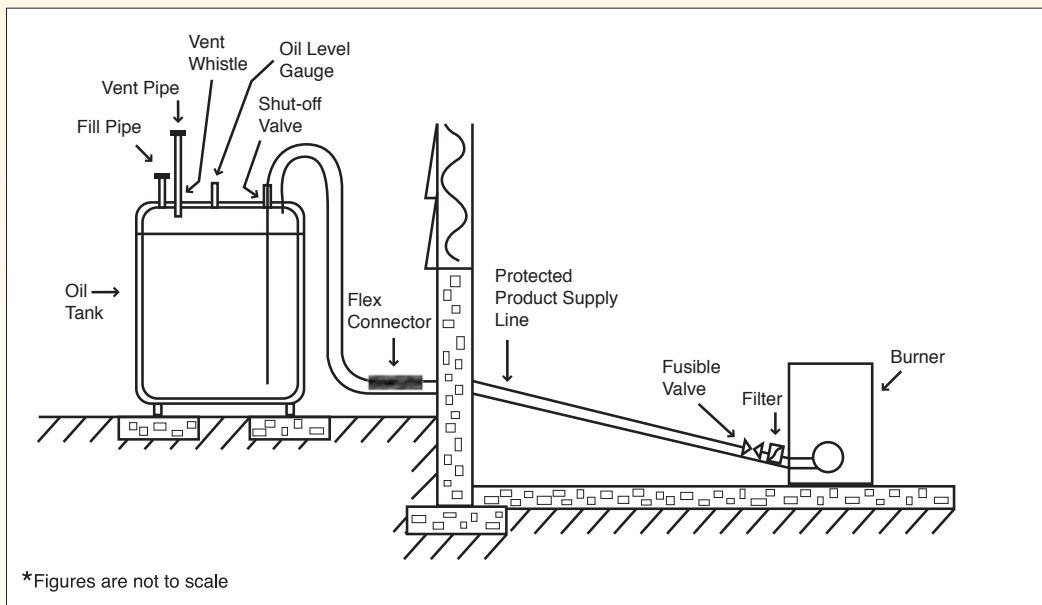
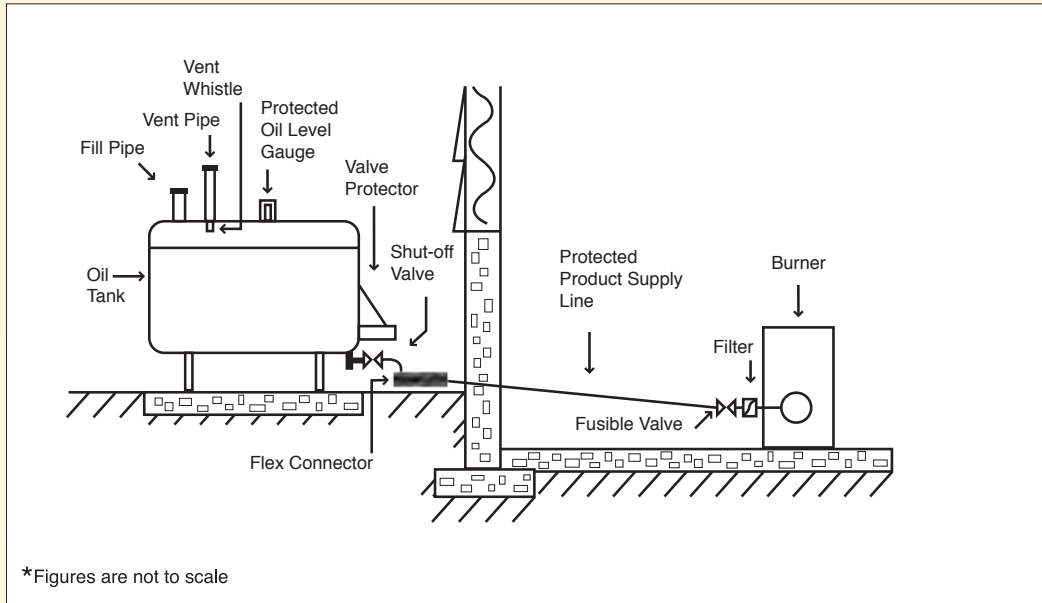

\*Illustrations have been adapted with permission from the Government of Nova Scotia



## 1.1 Use of this Guide

This Guide is not a legal document, nor is it intended to be a complete manual on the proper installation and maintenance of heating oil tanks and accessories. It does not guarantee proper functioning of the installation you are inspecting. As the homeowner, you are responsible for ensuring that your heating oil tank is inspected and serviced by a *Certified* Oil Burner Mechanic to guarantee proper functioning.

This Guide is provided by the Department of Environment and Natural Resources (ENR), Government of the Northwest Territories (GNWT) as a courtesy only. It is intended to provide homeowners with information on the important areas where maintenance or risk prevention is advisable.

This Guide can be used by homeowners, commercial building owners and/or property managers, and anyone purchasing a new home. Many prospective home buyers give little or no thought to the condition and age of the heating oil tank and associated fittings. Knowing the potential environmental and financial liabilities associated with inadequate heating oil tank installations before purchasing a home can save you a lot of trouble and money down the road.

Prospective home buyers are *strongly* advised to get a Certified Oil Burner Mechanic to do an inspection of the heating oil tank and accessories to ensure any potential problems can be caught early, *before* they become costly.



## 2. YOUR ROLES AND RESPONSIBILITIES

Regular inspection of your heating oil tank is important because:

1. Failure to do so could cost you a lot of money.
2. You will be helping to protect the environment.
3. It is your legal responsibility.

Under the NWT's *Environmental Protection Act*, the owner or person in charge, management or control of a contaminant (in this case heating oil) is ultimately responsible for preventing the discharge of a contaminant into the environment by ensuring that

the heating oil tank and accessories are kept in good working order and are in compliance with current regulations and codes of practice. This involves *all* the properties that the oil contaminates.

In the event of an oil spill, the homeowner is legally responsible for the costs associated with the spill, cleaning up the spill, notifying anyone who might be affected, restoring the affected land to a condition that meets acceptable environmental standards, and repairing any of the damage caused by the spill. Failure to do so can result in legal action.





## 3. CASE STUDIES

### 3.1 Indoor Spill

*A homeowner moved his heating oil tank from inside the home to outside. The work went well, however, the homeowner did not remove or seal the old fill pipe.*

*During the next fuel delivery approximately 110 litres of heating oil was emptied directly into the basement.*

*As a result, a number of boxes of household goods were contaminated and had to be disposed of, and due to the strong smell of fuel oil, the occupants of the home had to move into a hotel. Absorbent pads had to be purchased to clean up the fuel oil, and a local steam cleaning company was hired to clean and deodorize the home. This resulted in thousands of dollars in damage and cleanup costs for the homeowner.*

This spill could have been prevented. The homeowner should have informed the oil distribution company of the relocated heating oil tank. A sign on the exterior of the house, or speaking directly to the delivery worker, is sufficient to warn the delivery person of the relocated tank. In addition, the old fill pipe should have been removed from the house when the tank was disconnected and moved.

### 3.2 Outdoor Spill

*A homeowner was out of town on vacation during the spring melt. The outdoor oil tank developed a pinhole leak and failed. This drained about 1,100 litres of heating oil into the yard. The furnace quit and the pipes in the home froze. Due to spring runoff, the oil travelled and contaminated three adjacent yards. The neighbours noticed the problem and reported it. When the homeowner returned, she had no fuel, frozen pipes and a huge mess to clean up. Her insurance provider refused to pay for the cleanup. The cost of cleanup came to over \$40,000.*

This situation could have been avoided with regular inspections. In addition to the expenses involved in cleaning up properties immediately following a spill, a spill itself often decreases the value of the home, making it harder to sell. Homeowners are *strongly* encouraged to conduct regular inspections, and schedule annual heating oil tank inspections by a Certified Oil Burner Mechanic during annual furnace or boiler servicing.



# 4. WHAT TO LOOK FOR

Proper care and maintenance of your fuel oil tank, lines and furnace can reduce the chance of an oil spill and costly environmental problems. Fuel oil spills in residential areas can:

- contaminate drinking water, groundwater and soil;
- cause odour and health problems in the home; and
- contaminate storm water drains, sewers, drainage ditches and surface water.

Often, this can cost thousands of dollars to correct. To avoid costly repairs and problems associated with leaks and spills from home heating oil systems, follow these tips when inspecting your tank and heating equipment. It is recommended that you make inspections before *and* during the heating season.

## 4.1 Certification Plates

All heating oil tanks must comply with national construction standards (CAN 4-S602). This is usually indicated on the tank via a metal plate indicating it has ULC (Underwriters' Laboratories of Canada), UL (Underwriters' Laboratories [USA]) or CSA

(Canadian Standards Association) certification. **DO NOT** paint over this plate! Your insurance company may require proof of this certification before they will provide homeowner coverage.

Heating oil tanks must be installed in accordance with CAN/CSA B139-04 Installation Code for Oil-Burning Equipment. If in doubt, consult a Certified Oil Burner Mechanic.

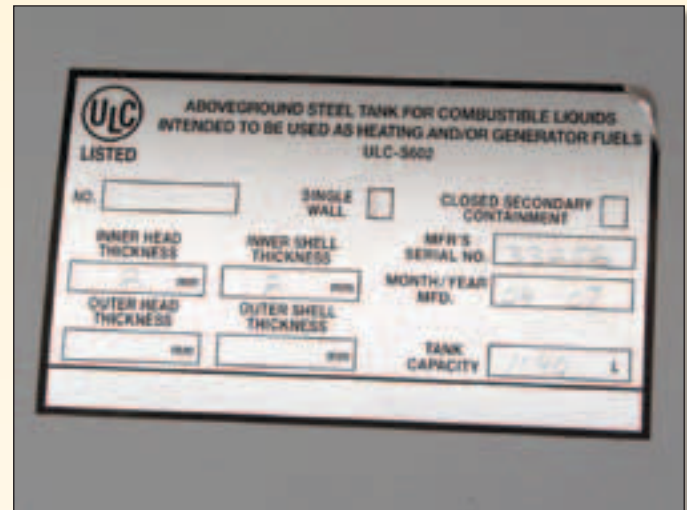

*ULC certification plate.*

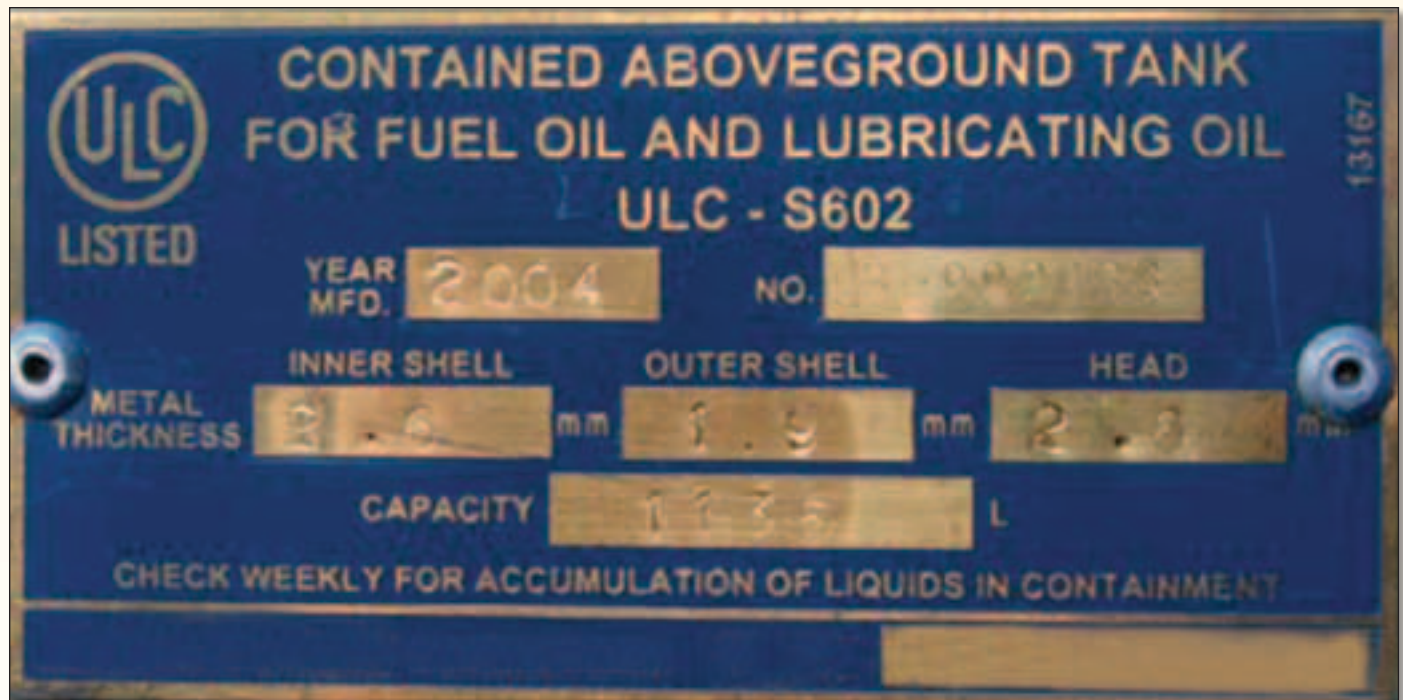

*ULC certification plate for a double-wall steel heating oil tank. (Photo courtesy of the Government of Nunavut.)*



## 4.2 Rusting/Corrosion/Dents/ Physical Damage

Some surface rusting on steel heating oil tanks is normal. The internal rusting and corrosion that can lead to spills is often unrelated to mild surface rusting. However, you should still check for surface rusting because excessive surface rusting may be an indication of corrosion and that your tank is old and in need of replacement. Check for any excessive denting or other signs of physical damage that may weaken the tank. This can make the tank more susceptible to rupture and leakage.

The most serious rust damage to oil tanks occurs from the inside out, due to annual condensation of water collecting on the bottom of the tank. Since there is no direct correlation between location of external and internal rust on oil tanks, it is extremely important that you take immediate corrective measures if there is any indication of internal rust such as a pinhole or leak. Even if the tank looks fine from the outside the steel may be extremely thin and weak in areas of internal rust. Be careful when running your hand over rust bubbles or spots on the tank that are damp. Do not attempt to remove rust or paint, or otherwise clean the bottom or sides of your tank when it contains oil. In a corroded tank, the slightest pressure can cause a leak.



*Single-wall, 1,135 litre (250 gallon), heating oil tank.  
Note the surface rusting.*

To prevent internal corrosion, oil tanks should be drained of accumulated water at least once a year. Early fall is a convenient time to remove the water from your oil tank; the same time as the pre-winter servicing of your furnace.

Several companies provide chemical indicator test kits to test for the presence of water in your oil tank. These products usually come in the form of thick pastes that are applied to dipsticks and inserted into the tank. The paste turns a florescent colour upon contact with water. Some products that disperse and absorb residual water in the tank also exist to help prevent corrosion.

Additional methods include keeping your tank relatively full over the summer, asking your fuel company about fuel additives that prevent water condensation and the use of sacrificial anodes. Anodes are made of a more active metal than that of the tank and come in the form of balls or rods. Because they will corrode before the tank walls, anodes can extend the life of your tank.

The use of these products should be seen as an additional step in the removal of water from oil tanks and not be seen as a substitute for regular, proper, draining. Consult a Certified Oil Burner Mechanic before using these products or with any questions or concerns regarding water build-up and tank corrosion.

Oil tanks should also be inspected for obvious signs of damage, including dents, bent or pinched lines, cross-threaded fittings, broken or cracked fill gauge, cracked or weeping weld seams and/or broken or heaved base support. These types of damages can increase the chance of corrosion, oil supply line failure, threaded joint failure, weld failure and/or tank upset. To prevent exterior tank corrosion, never store material against your oil tank and remove any debris such as tall grass, leaves, insect nests, ice and snow.

### 4.3 Drip Leg

Some oil tank installations have drip legs. A drip leg is a section of pipe that protrudes at a right angle from the main fuel line and extends below the level of the bottom of the fuel tank. Water naturally collects in this space, before it accumulates in the bottom of the tank, making it easier to remove. Orienting the tank on its stand so that it is tipped forward slightly aids in drainage.

Drip legs should be drained at least once a year to prevent the accumulated water from freezing and bursting the drip leg. When this happens, the contents of the fuel tank quickly drain onto the ground. It is strongly recommended that a Certified Oil Burner Mechanic performs this task at least once a year.

To prevent fuel from spilling out while the drip leg is being drained, it is recommended that a shut-off

valve be installed in the section of fuel line between the tank and the drip leg. Most tanks with drip legs are equipped with one. Ensure the bottom of the drip leg is fitted with a screw-on end cap that cannot be moved by hand. This prevents tampering by vandals or children.

The larger the diameter of the drip leg, the less likely it is to rupture if the contents freeze. A diameter of two inches is recommended. Drip legs with a diameter of one inch or less *tend* to rupture when frozen, allowing the fuel to escape from the tank. To help prevent ruptures and increase the capacity of drip legs less than two inches in diameter, ensure they are as long as possible.

A drip leg is a precautionary measure and should not be viewed as a substitute for regular draining of water from the fuel tank.

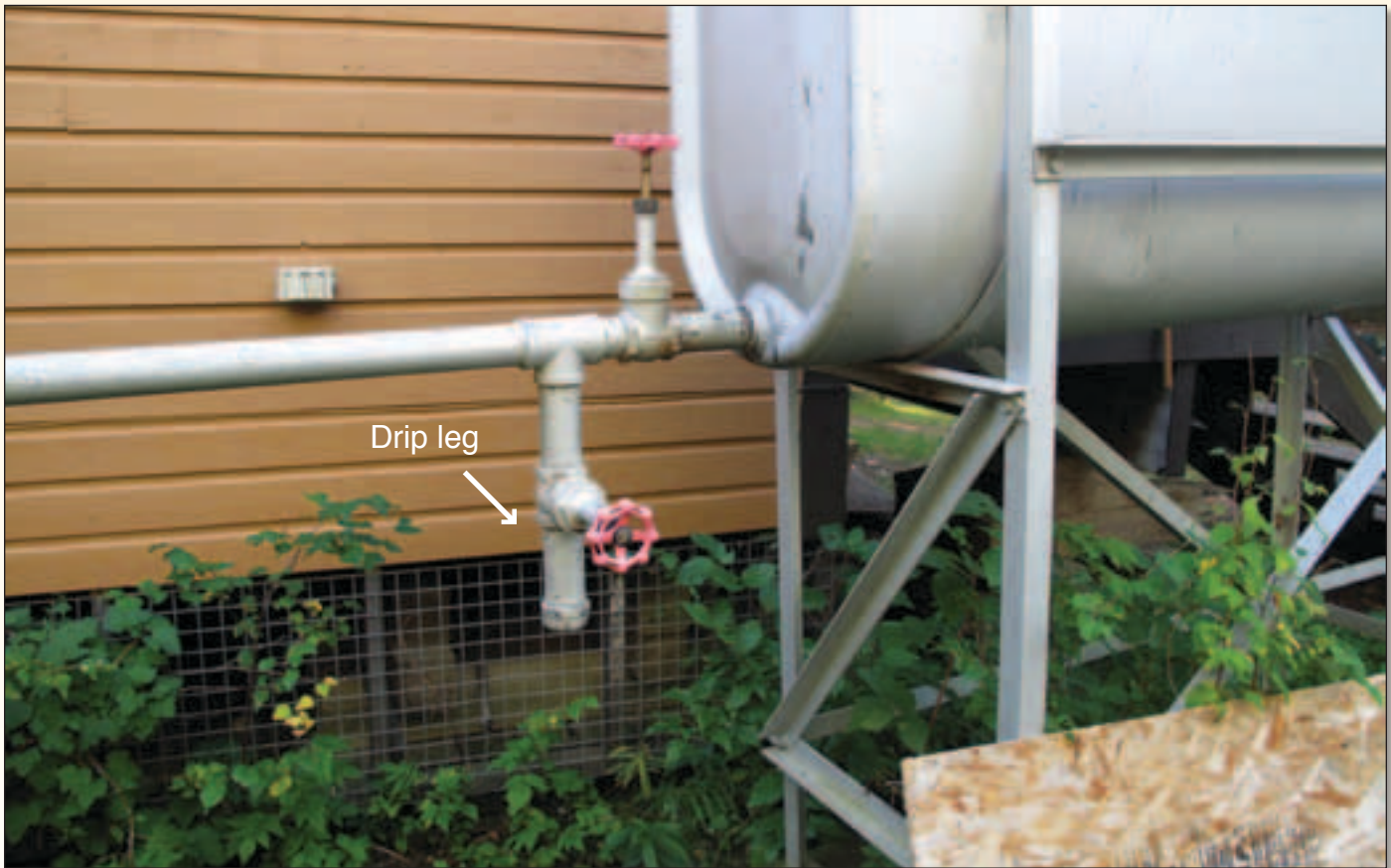

*Drip leg extends below the level of the fuel line.*

## 4.4 Tank Stand

When full, a fuel tank with a 1,135 litre capacity weighs about one tonne. Unless properly anchored, a standard metal tank is inherently unstable because it is top-heavy. Tank stands should be bolted to solid footing and/or possess a very broad base.

The ideal foundation for a tank is a large concrete pad with a metal tank stand firmly bolted down. Wooden tank stands are prohibited under the National Fire Code of Canada.

Do not fasten the oil tank to the siding of a building because it is not strong enough to hold the tank in place. An unstable tank can easily pull away from the siding as it falls over.

Fuel tanks are particularly susceptible to toppling over during the spring when the flow of melt water can undermine bases and stands. To prevent this, put the stand on a well-drained location and not in the path of spring melt water channels.

Other threats to residential oil tank stands involve wind and the weight of ice, snow or children climbing on them. Safeguarding your tank will prevent it from toppling and spilling out its contents.

If you are using two cross-connected tanks, they must be placed on the same pad. *Note:* Patio stones cannot be used as a base for cross-connected tanks.



*Epoxy-coated, 1,135 litre (250 gallon), single-wall steel heating oil tank on metal tank stand.*



*This flex connector is out of alignment.*

## 4.5 Flex Connectors

Flex connectors are designed and intended to allow for minor shifting of either the heating oil tank stand and/or the building. *They are not intended to compensate for misaligned fittings.* A properly installed flex connector should be aligned in a straight line. If the flex connector is “S” shaped or out of line, it has served its purpose – accommodating the shifting. It is now time to realign the tank and fittings.

The steel weave or corrugation of the flex connector provides its strength. It must fit tightly around the inner lining. The flex connector should not be compressed along its long axis. You can check for this by grasping it with your hand. If the metal weave is loose and you can compress the weave by hand, then the flex connector needs to be replaced.

When in doubt, talk to a Certified Oil Burner Mechanic.



## 4.6 Fittings and Valves

All fittings and valves should be regularly inspected for rust, corrosion or other physical defects. Be sure to check for signs of leakage or weeping (when a thin film of oil develops around the joints). If you find or suspect any of these defects, contact a Certified Oil Burner Mechanic to inspect and/or repair the defect as soon as possible.

Ensure your appliance has been fitted with safety valves such as Firromatic safety valves. These valves shut off the flow of oil to the furnace in the event of a fire. There should be one of these valves on the fuel line at the oil burner. Putting an additional safety valve at the oil tank is also a good idea.



*Small spill from a leaking valve.*



*Broken valve on oil tank in basement.*



*Newly installed oil tank valve. Note the oil stained ground still requiring clean-up.*

## 4.7 Fuel Lines

A fuel line connects your heating oil tank to your furnace or boiler. Ideally, your fuel line should be as short as possible. Longer fuel lines are more susceptible to damage from vandalism, weather, ground shifting, etc.

If you must use a long fuel line, ensure it is structurally supported along the entire length. This will prevent shifting and rupturing and provide easy access for inspection. All fuel line connections, including oil filters, should be clean and tight. Oil filters are located between your burner and oil tank, and filter out dirt and impurities. Homeowners are *strongly* encouraged to conduct regular inspections of their fuel line and schedule annual inspections by a Certified Oil Burner Mechanic.

Buried fuel lines should be avoided because they are even more susceptible to rupturing and difficult to inspect. Often, a significant volume of heating oil is spilled as a result of ruptures in underground fuel lines and goes undetected for months; developing into a very costly cleanup.



*This type of fuel line is called a swing joint, which accounts for tank movement.*

An often over-looked aspect of fuel line installation is protection from falling ice. Fuel lines located below the slope of a roof are subject to breakage from falling and/or accumulating ice. If possible, re-route any lines that are subject to this hazard or find a means to protect them. This also holds true for the heating oil tank itself.

Accumulated drifting snow can also damage your oil tank, adding a considerable amount of weight to the tank, often enough to rupture an unprotected fuel line. A rupture is most likely to occur along the weakest section of the line, typically the flex connector. Clearing drifting snow from the fuel lines can prevent rupturing and will ensure the lines are visible for inspection. An alternative is to relocate your fuel tank and lines to an area that is less subject to drifting snow. If a leak occurs while the line is buried in snow, it can remain undetected for months.



*Broken fuel line at elbow due to stress from shifting oil tank.*



## 4.8 Fill and Vent Pipes, Caps and Vent Whistles

Do not obstruct the fill and vent pipes at any time, for any reason. Fill and vent pipes should be part of regular inspections. Clear any snow, leaves, insect nests or other debris from the vent and fill pipes to allow the tank to vent properly and ensure accessibility for the delivery person. Inspect the vent and fill pipes and the bottom of the tank before and after each fill. Leaks, spills and obstructions may not be apparent until there is a change in volume.

Fit your tank with a vent whistle. These devices are installed at the base of the vent pipe and protrude several inches into the tank. The tail end of the vent whistle protrudes into the oil tank; the vent pipe screws into the top of the vent whistle. While the tank is being filled they whistle, similar to a tea kettle. The noise stops once the level of oil reaches the bottom of the whistle. This signals that the tank is full and the delivery person can turn off the flow of oil. Your delivery service can advise you if your vent whistle

is working properly. Installing a vent whistle ensures your tank will retain some valuable headspace when it is filled. Headspace is a gap between the level of oil and the top of the tank, allowing for thermal expansion of the oil. This will be discussed further in Section 6.1 of this Guide.

Vent whistles are inexpensive and easy to install. Most reputable plumbing and installation firms automatically include a vent whistle on any new heating oil tank installation. Discuss this with your service provider.

All vent and fill pipes should be fitted with rain caps. This prevents water from entering the tank. Fill pipe caps should be affixed to the fill pipe with a hinged arrangement to prevent accidental loss of the cap. Most fill pipe caps can be locked to prevent tampering and/or theft of heating oil.



## 4.9 Drips and Ground Staining

Excessive ground staining may be a sign of dripping, chronic spillage from the tank being overfilled or leakage. Any evidence of leaks and/or drips should be repaired immediately. Contaminated soil is the homeowner's legal responsibility to clean up. Many banks and other lending institutions will not finance the purchase of a home if there is ground staining or other oil spill damage.

Potential home buyers are strongly advised to inspect the area around the heating oil tank for signs of past chronic oil spillage. This inspection should be followed up with a professional inspection, by a qualified building inspector or engineer. Your insurance provider can advise you on this.

To protect the ground or floor below the oil tank, a drip tray can be placed under the tank to intercept potential oil drips. Some of these devices come with built-in alarms that alert the homeowner to the presence of a drip.



*Leaking oil tank. Note the steady stream of oil from a pin-hole leak.*



*Attempt to capture oil leak. Note the dead vegetation around the tank.*



## 4.10 Oil Level Gauge

All oil tanks must be fitted with a fully functional oil level gauge. The easiest way to ensure your oil level gauge is working is to monitor it for a few weeks during the winter. If the reading does not change, there may be a problem with your gauge. Oil level gauges can become cracked, stuck or frozen. Broken or malfunctioning gauges should be replaced or repaired as soon as possible. Your gauge should be equipped with a heavy, steel gauge protector to prevent accidental damage from vandalism, falling ice and other accidents.

Unfortunately, oil level gauges are subject to malfunctions. It is strongly recommended that a vent whistle be installed so that a back-up system is in place (refer to Section 4.8).



*Oil level gauge. Note the empty tank.*

## 4.11 Secondary Containment

In the event of an oil tank spill, secondary containment structures, also called containment berms, prevent heating oil from escaping into the environment.

The National Fire Code of Canada requires secondary containment of tanks with a capacity greater than 2,500 litres. Most residential tanks are 1,135 litres. Secondary containment is required to have a capacity of 110% of the volume of the oil tank it is enclosing. In other words, a tank with a capacity of 2,500 litres requires secondary containment with a volume of 2,750 litres.

Secondary containment structures should be kept free of accumulated water and debris. Most of these structures are fitted with a drain valve to release accumulated water. This valve should be fitted with a lock or the spout should be fitted with a pipe plug or pipe cap to prevent tampering by vandals and children. Before draining accumulated water, ensure that it does not also contain heating oil. If it does, ensure its proper removal and disposal before draining the water.

Beginning July 1, 2010, all outdoor steel tanks must be double-wall tanks. For more information about impending changes to the new *B139-09 Installation Code for Oil Burning Equipment*, including changes to secondary containment rules, see page 2 or page 25.

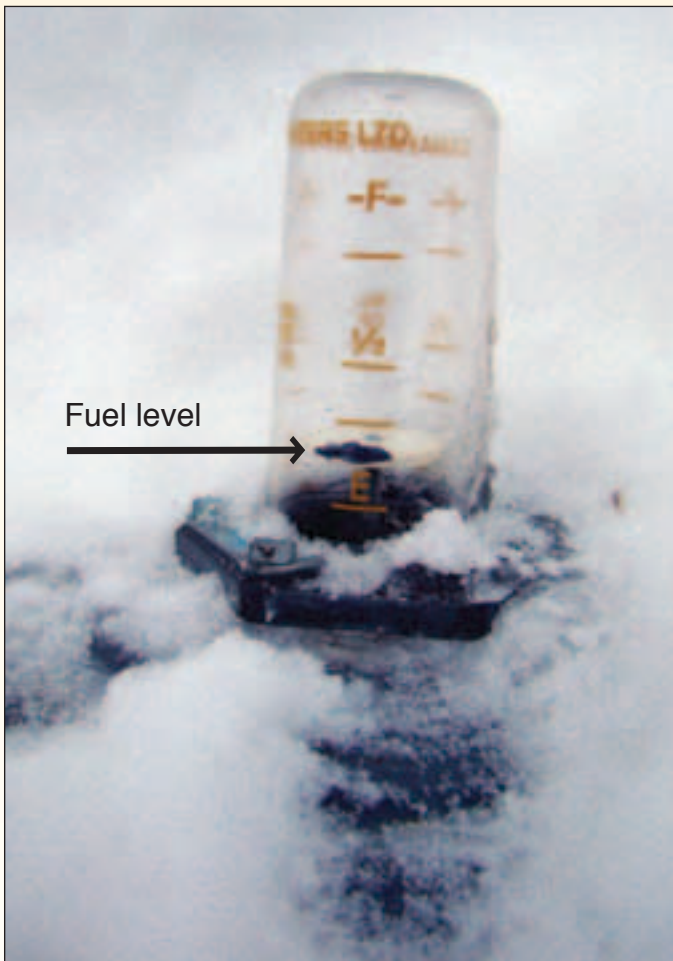

*Oil level gauge.*



## 4.12 Tank Location

Heating oil tanks should be located as close as possible to the heating appliance and in a location where it will be safe from vehicular impact and/or other physical hazards. A heating oil tank in an unsafe location should be moved without delay. If relocation is not an option, the tank should be protected with a solid, immovable barrier such as steel-concrete posts anchored into the ground.

Your heating oil tank should be located indoors wherever possible, as this protects the tank from hazards, including falling ice and snow, external corrosion, vandalism, ground shifting, running water and vehicular impacts. Fuel oil that is stored indoors is kept warm and burns more efficiently.

Indoor tanks should be located in the lowest level of the building, i.e.: crawlspace or basement. An exception to this is if they are located in an attached garage that is not the lowest floor.

If it is impossible to install your heating oil tank indoors, it should be kept as well protected as possible. Indoor tanks should be regularly inspected for signs of leakage such as oil stains and odours in the basement.

Outdoor oil tanks should be located above ground. Above ground tanks are much easier to monitor and maintain and spills are much easier to detect at an early stage. Underground tanks should be monitored for oil consumption and compared to previous years. It should also have secondary containment. A leaking underground tank may explain sudden increases in consumption.

Outdoor above ground tanks should never block doorways and windows (including basement windows). As a courtesy to your fuel service provider, pathways and steps leading up to your heating oil tank fill pipe should be free of snow and other debris. Tanks must also respect the local code for distance from property lines and other energy source connection lines and storage systems (such as power poles).



*Typical oil tank location.*

# 5. REPLACING YOUR HEATING OIL TANK

Eventually, due to age and wear and tear, your oil tank will need to be replaced. Most insurance companies require heating oil tanks be replaced at least every 10 years. Check with your insurance provider for their standards.

There are three basic outlet types associated with home heating oil tanks: top, end and bottom outlets. Top outlet tanks typically rely on a combination of siphoning/oil pump action to draw oil to the heating appliance burner, while end and bottom outlet tanks typically use a combination of gravity fed/oil pump action to deliver the oil to the furnace or boiler.

When replacing your heating oil tank, several options exist:

## 5.1 Single-wall Steel Heating Oil Tank

This is generally the least expensive option. However, these tanks are susceptible to corrosion from both the outside and the inside of the tank.

## 5.2 Epoxy-coated, Single-wall Steel Heating Oil Tank

The epoxy-coated single-wall steel heating oil tank is more durable and more expensive than the uncoated variety. The epoxy paint provides increased protection from external corrosion and an increased lifespan. These tanks are not coated on the inside, making them susceptible to internal corrosion from accumulated water.

## 5.3 Double-wall Steel Heating Oil Tank

The double-wall steel tank has increased durability, but is more expensive than single-walled tanks.

A double-wall tank has an interstitial space between the two tank walls, meaning the outer tank has a volume larger than that of the inner tank. If the inner tank corrodes, oil will fill the outer tank and not spill onto the ground. However, water must still be drained from the inner tank on a regular basis.



*Double-wall steel heating oil tank.*

A double wall tank must be fitted with an inspection port to allow for easy, regular monitoring of the interstitial space for any signs of leaks.

#### 5.4 Double-wall Steel and Polyethylene Heating Oil Tank

Similar to the double-wall steel tank, this tank also has an interstitial space between the two tank walls. The difference is the outer tank is made of galvanized steel that is corrosion resistant and the inner tank is made of high density polyethylene. The tank can be fitted with an optical leak alarm. The outlet for this tank is on the top.

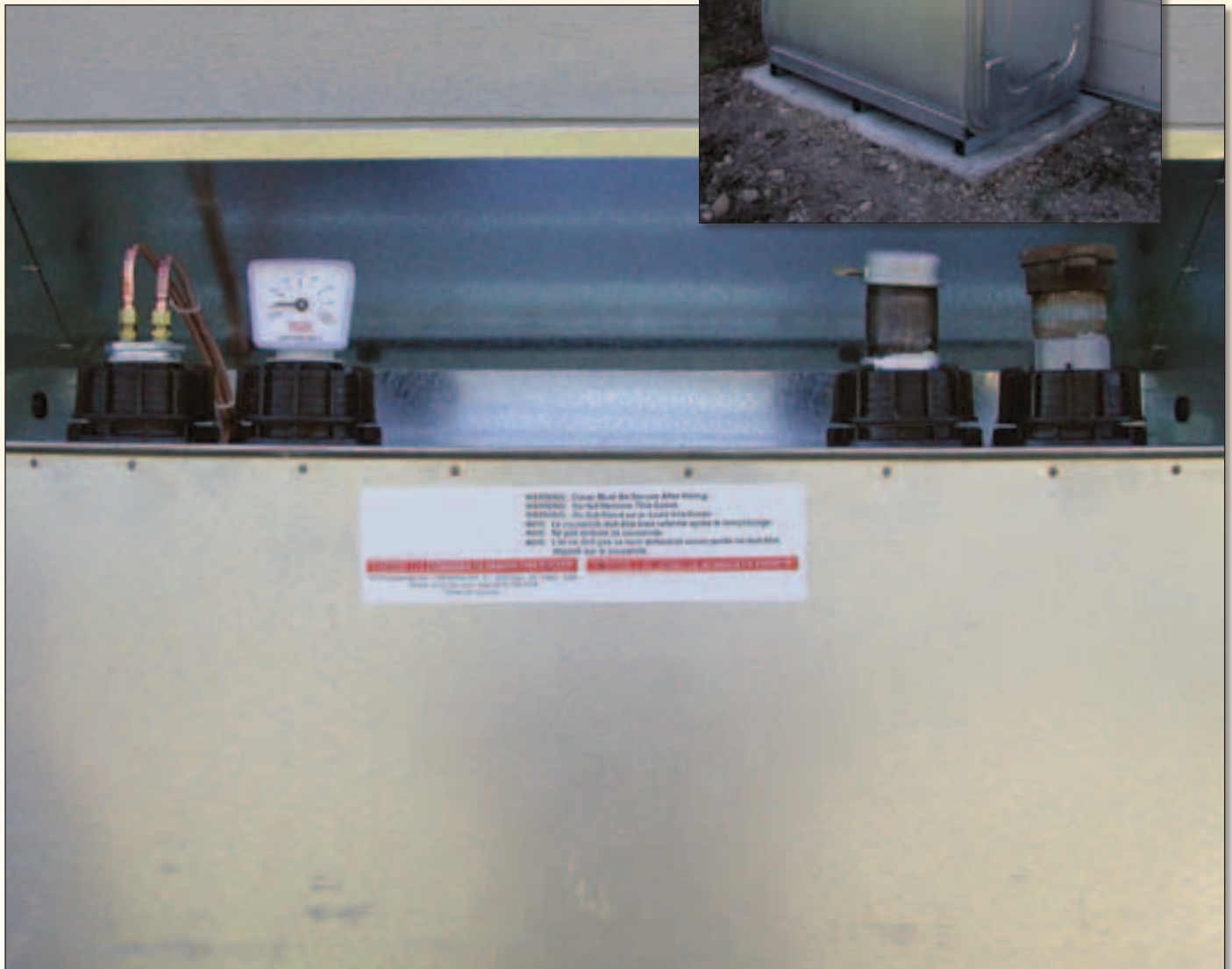

*The tank cover protects the fill pipe, vent pipe, fuel level gauge and fuel lines from exposure to the elements.*



### 5.5 Fibreglass Heating Oil Tank

Fibreglass heating oil tanks have many attractive features, but are more expensive than typical steel tanks. These oil tanks resist rust and corrosion much more effectively than steel tanks and can last longer than steel tanks. Fibreglass tanks come in both single-wall and double-wall construction and are lightweight compared to steel, weighing approximately 90 kg (190 lbs) for a single-wall 1,135 litre tank (250 gallon). As with all tanks, accumulated water must be drained on a regular basis. Double-wall tanks should be fitted with an inspection port. See photo below.

### 5.6 Used/Second-hand Heating Oil Tanks

Purchasing used/second-hand heating oil tanks is not recommended. The costs saved purchasing a second-hand tank are negligible in the face of the costs associated with the clean up a spill from a sub-standard tank. A homeowner takes a great risk in installing a used or second-hand tank because it is difficult to assess the tank's structural integrity. Insurance companies may refuse to insure used or second-hand tanks.

### 5.7 Which Option Should You Choose?

Several factors, including budget, tank location, your insurance policy and the advice of a local Certified Oil Burner Mechanic must be considered when purchasing an oil tank. Given the high environmental and financial cost of an oil spill, homeowners are urged to place a high priority on quality when choosing a new tank.

Only the most common oil tanks are featured here. Additional research into the different tanks available, and consultation with your insurance provider and local installer, can help you determine the most appropriate oil tank to install.

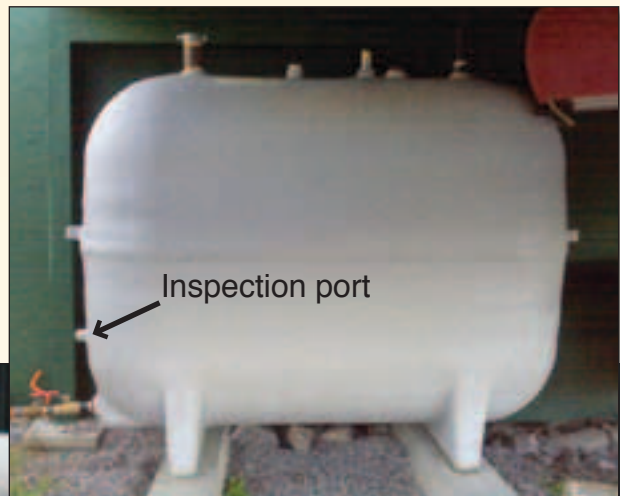

*Top: Fibreglass heating oil tank on concrete stands. Bottom: Fibreglass heating oil tank. Note the concrete barrier protecting the tank.*

# 6. OTHER CONSIDERATIONS

## 6.1 Thermal Expansion

Heating oil expands and contracts as it is subjected to temperature changes, which can cause oil leaks and ruptures. Homeowners should pay particular attention to this, especially when the weather is variable in the spring and fall.

These leaks occur when a tank is filled during a cold period, followed by a warm period. The heating oil in the tank expands when temperatures increase. If there is not sufficient headspace in the tank (as described in Subsection 4.8), the oil can expand, back up the fill pipe and spill onto the ground. These types of spills are usually only a couple of litres. However, it can have the same effect as a larger spill if it occurs on a regular basis. In addition to being a waste of an expensive, finite resource, the homeowner is responsible for the cleanup.

The most effective way to prevent these types of spills is to ensure ample headspace is always retained between the fuel level and the top of the tank. As recommended in Subsection 4.8, a vent whistle provides an inexpensive way of ensuring this headspace is retained.

While fuel delivery nozzles are equipped with an automatic shut off, there is no substitute for human supervision ensuring against an overflow or other mishap. *The person delivering the heating oil is required to stay with the fuel nozzle at all times during the re-fuelling of your heating oil tank.* Any violations should be reported to your local Renewable Resource Officer or Environment and Natural Resources Office.

## 6.2 Transfer of Product

When replacing your oil tank, transferring old product to your new tank should be avoided, to prevent premature tank failure. Due to the presence of sludge, acids, microorganisms and water, new tanks are initially more susceptible to rusting.

If it is impossible to avoid transfer of old product to your new tank, follow the tank manufacturers recommended practices for product transfer. Transfer of product should only be done by a professional. Plan ahead and burn down the fuel level in your tank to allow the least amount of necessary product transfer as possible. The remaining sludge and water must be disposed of in accordance with current regulations. Sludge is considered a hazardous waste and proper treatment is outlined in the Environmental Guideline for Industrial Waste Discharges. A Certified Oil Burner Mechanic can provide the appropriate information on transferring product.

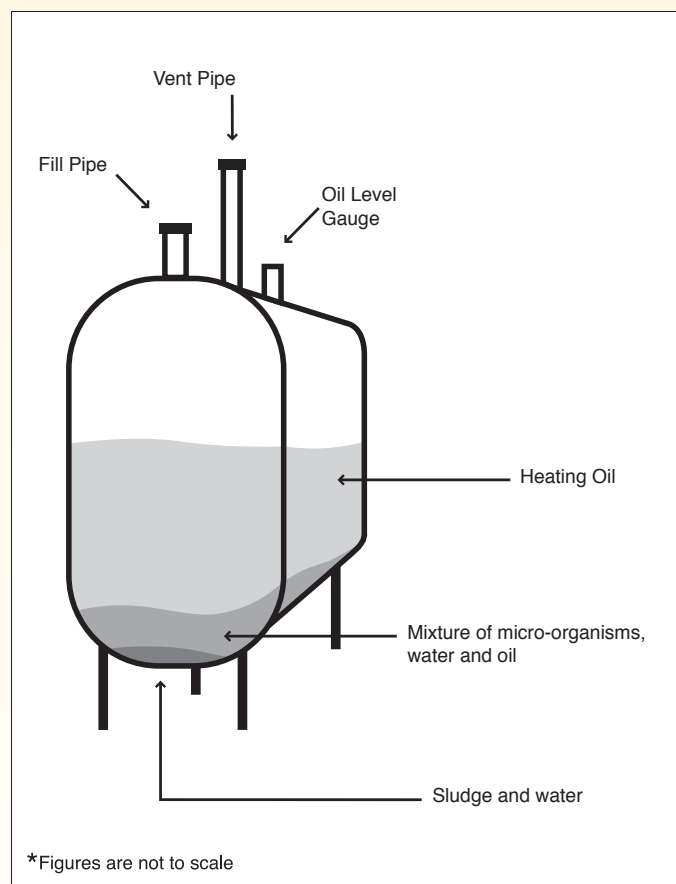



### 6.3 Tank Movement and Levelling

Unless necessary, oil tanks should never be moved. If you do need to move your tank, wait until it is empty. Never drag or drop your tank.

Tanks shipped directly from a manufacturer typically come with tank opening caps or plugs to protect the fitting threads. All caps/plugs should be removed and the tank should not be filled unless properly installed. Any condensation or ice formed in the tank during shipping and storage should be removed before installation.



### 6.4 Insurance Considerations

Insurance companies may have different standards and requirements regarding oil tanks. Check with your insurance provider for information and guidelines. Most insurance providers require oil tanks be free of rust and have no signs of leakage. Many companies also require proof of certification plates, often from a specified certification body (CSA, ULC or Warnock Hersey). Other considerations include a requirement for tanks to be located off the ground on a stand, for fuel lines to have a protective cover and for tanks to be located away from high traffic areas. However, these are generalizations only. Contact your insurance provider for a complete list of requirements.

Many insurance companies *do not provide coverage for the cleanup of contaminated soil in your yard*. Your policy may cover your neighbour's yard, or damage to your house, but it *may not* cover your own yard. As cleanup of contaminated soil can cost in the tens to hundreds of thousands of dollars, it is *strongly* recommended that you take care of your heating oil tank and find out if your insurance covers the costs associated with cleaning up a spill on your property.

As a general rule of thumb, *if the spill was preventable with regular maintenance and inspections, insurance companies are unlikely to pay for cleanup costs*.

# 7. SPILLS

In the event of a spill, your main priorities are to stop the flow of oil at its source by turning off the shut-off valve, plugging the hole, placing a bucket under the oil leak and containing the oil that has already spilled. These actions will minimize the impact of the spill on the environment, your property and that of your neighbours. In most cases, cleanup costs consist of the removal and disposal of contaminated soil and replacement of your oil tank. Check with your insurance provider to find out if your policy covers heating oil tank spills.

## 7.1 First Response

If you discover a leak:

1. Turn off the power to your furnace at the emergency switch for the oil burner.
2. Stop the leak, if it is safe to do so.
  - a. Heating oil is flammable, do not smoke or use any flame nearby.
  - b. Fumes from spilled oil can accumulate in confined spaces and be very dangerous. Call your local fire department if you need assistance.
3. Contain spilled oil using whatever materials are available (pails, rags, newspapers, peat moss, kitty litter, absorbent pads, sheets of plastic, etc). Do not flush spilled oil or contaminated materials down the drain or sewer.
4. Call your heating oil supplier for help in transferring any remaining oil from the leaking tank to a 45-gallon drum.
5. Notify the **24-hour Spill Report Line at (867) 920-8130** if the heating oil spill is over 100 litres (20 gallons).
6. Clean up spilled oil and any contaminated soil and place in plastic pails or strong garbage bags.
7. Properly dispose of any recovered oil, contaminated soil, other contaminated materials and containers at the designated facility/location in your community.
8. Call the Department of Environment and Natural Resources (ENR) in Yellowknife, at (867) 873-7654, or your Regional Environment and Natural Resources office for information on disposing of contaminated soil as movement documents are required for soil transfers.
9. Contact your insurance provider as soon as possible.



*ENR Renewable Resource Officer investigating an oil spill.*

## 7.2 Reporting Spills

***Heating oil spills of 100 litres (20 gallons) or more must be reported to the 24-hour Spill Report Line.\****

There are two ways to do this:

1. Call (867) 920-8130 and report the spill. *Collect calls are accepted.* You will be required to provide your name, address, telephone number, where the spill occurred, how much was spilled and the cause of the spill.
2. Fill out the spill report form attached to this Guide and fax it to the Spill Line at (867) 873-6924. Interactive spill report forms are also available electronically and can be filled out online, printed and faxed or e-mailed to the Spill Line. Interactive electronic spill report forms are available upon request or can be downloaded from the ENR web site at [http://www.enr.gov.nt.ca/\\_live/pages/wpPages/Hazardous\\_Materials\\_Spill\\_Database.aspx](http://www.enr.gov.nt.ca/_live/pages/wpPages/Hazardous_Materials_Spill_Database.aspx)

\*Please note that while heating oil spills of less than 100 litres are not *reportable*, **all** spills of hazardous materials, including heating oil, must be cleaned up *regardless* of the quantity involved.

This Guide is intended to educate prospective and current homeowners, commercial building owners and/or property managers about the importance of regular heating oil tank inspections to prevent leaks

and spills that can be harmful to people, property and the environment. It is the legal and financial obligation of the owner to report and clean up the spill.

Residents can significantly reduce the number and volume of spills from home heating oil tanks by following the steps in this Guide. Sharing this information with family, friends and neighbours will also help protect you, your property and the environment from heating oil spills.

Any questions or suggestions for improvements to this Guide are encouraged and should be directed to:

Environment Division  
Department of Environment and  
Natural Resources  
Government of the Northwest Territories  
P.O. Box 1320  
Yellowknife, NT X1A 2L9  
Tel: (867) 873-7654  
Fax: (867) 873-0221

Or your Regional ENR Office at:

Inuvik..... (867) 678-6652  
Norman Wells ..... (867) 587-3515  
Fort Simpson..... (867) 695-7477  
Yellowknife ..... (867) 920-3387  
Hay River ..... (867) 875-5571



*Spill cleanup.*



*Soil sampling for a spill investigation.*



# 8. LEGISLATION, CODES AND STANDARDS

## Legislation

Government of the Northwest Territories

- *Environmental Protection Act*
  - *Environmental Guideline for Industrial Waste Discharges*
- *Spill Contingency Planning and Reporting Regulations*
- *Used Oil and Waste Fuel Management Regulations*

The above listed legislation and regulations are available at [http://www.enr.gov.nt.ca/\\_live/pages/wpPages/legislation.aspx](http://www.enr.gov.nt.ca/_live/pages/wpPages/legislation.aspx) or by contacting your local Renewable Resource Officer/Environment and Natural Resources Office.

Government of Canada

- *Storage Tank Systems for Petroleum Products and Allied Petroleum Products Regulations*  
<http://www.ec.gc.ca/st-rs/>

This legislation does not affect private homeowners (unless they are situated on Federal Land). However, it contains useful information.

## Codes

The following Codes cannot be accessed online  
To purchase from the National Research Council Canada, go to:

- *National Fire Code of Canada 2005*  
<http://www.orderline.com/detail.asp?group=3763>
- *National Building Code of Canada 2005*  
<http://www.orderline.com/detail.asp?group=3762>

Or check out your local bookstore.

## Standards

Underwriters' Laboratory of Canada (ULC)

- National Standard of Canada. CAN/ULC-S602-03, *Aboveground Steel Tanks for the Storage of Combustible Liquids Intended To Be Used as Heating and/or Generator Fuels.*  
<http://www.orderline.com/detail.asp?group=448>
- Underwriters' Laboratories of Canada. ULC/ORD-C80.1-00, *Aboveground Non-metallic Tanks for Fuel Oil.*  
<http://www.orderline.com/detail.asp?group=338>

Canadian Standards Association (CSA)

- Canadian Standards Association, *Installation Code for Oil Burning Equipment (CSA B-139-04).*  
<http://www.shopcsa.ca>
- Canadian Standards Association, *Installation Code for Oil Burning Equipment (CSA B-139-09).*  
<http://www.shopcsa.ca>

## Office of the Fire Marshal

Department of Municipal and Community Affairs  
Government of the Northwest Territories  
PO Box 1320  
600-5201 – 50th Avenue  
Yellowknife NT X1A 3S9  
Fire Marshal's Office .....867-873-7469  
Project Plan Review .....867-873-7030  
Fax.....867-873-0260

Or the Assistant Fire Marshal Regional Office at:

Inuvik.....867-777-7297  
Norman Wells .....867-587-7115  
Fort Simpson.....867-695-7230  
Fort Smith.....867-872-6535  
Yellowknife .....867-920-8081

## 9. REFERENCES

Bay of Quinte Mutual Insurance Co.  
*How is your Oil Tank?*

<http://www.bayofquintemutual.com/HowIsYourOilTank.pdf>

Canadian Council of Ministers of the Environment.  
*Environmental Code of Practice for Aboveground and Underground Storage Tank Systems Containing Petroleum and Allied Petroleum Products.* 2003.

<http://www.ec.gc.ca/st-rs/default.asp?lang=En&n=06EF27CF-1>

Ecclesiastical Insurance Office.  
*Risk control bulletin (3) Oil tanks (above ground).*

[http://www.ecclesiastical.ca/Faith-Risk-Control-Kit/Oil\\_Tanks.pdf](http://www.ecclesiastical.ca/Faith-Risk-Control-Kit/Oil_Tanks.pdf)

Government of the Northwest Territories,  
Department of Environment and Natural Resources.  
*Check Your Heating Fuel Tank!*

[http://www.enr.gov.nt.ca/\\_live/documents/documentManagerUpload/check\\_your\\_heating\\_fuel\\_tank.pdf](http://www.enr.gov.nt.ca/_live/documents/documentManagerUpload/check_your_heating_fuel_tank.pdf)

Government of the Northwest Territories,  
Department of Environment and Natural Resources.  
*Environmental Protection Act.* 1999.

[http://www.enr.gov.nt.ca/\\_live/pages/wpPages/legislation.aspx](http://www.enr.gov.nt.ca/_live/pages/wpPages/legislation.aspx)

Government of the Northwest Territories,  
Department of Public Works and Services.  
*Good Building Practices for Northern Facilities.*  
May 2009.

<http://www.pws.gov.nt.ca/pdf/GBP/GBP%202009.pdf>

Government of Nova Scotia, Environment,  
Air, Land, Water.

*Taking Care of Your Tank.* March 2008.

<http://www.gov.ns.ca/nse/petroleum/oiltankmaintenance.asp>

Government of Nova Scotia,  
Environment and Labour.  
*Installation and Environmental Management Guide for Aboveground Domestic Oil Tanks in Nova Scotia.*  
March 2007.

<http://www.gov.ns.ca/nse/petroleum/docs/OilTankInstall.pdf>

Government of Nunavut,  
Department of Environment.  
*Illustrated Homeowner's Guide to Heating Oil Tank Inspections.* February 2008.

<http://www.gov.nu.ca/env/ogh.pdf>

Government of Ontario,  
Ministry of the Environment.  
*Green Tips. Residential Fuel Oil.* April 2008.  
<http://www.ene.gov.on.ca/cons/3676e.htm>

Northwest Territories Housing Corporation.  
Solutions to Educate People (STEP):  
*Home Maintenance/Repair.* 2007.

State of Alaska. Department of Environmental  
Conservation. Prevention and Emergency Response  
Program.

*Spill Prevention for Residential Heating Oil Tanks.*  
September 1999.

<http://www.dec.state.ak.us/SPAR/PERP/docs/facts.pdf>

Technical Standards and Safety Authority.  
*Advisory: Fuel Oil Distributors.* March 2002.



# APPENDIX

---

## **NT–NU Spill Report Form Instructions for Completing the NT-NU Spill Report Form**





Canada

# NT-NU SPILL REPORT

OIL, GASOLINE, CHEMICALS AND OTHER HAZARDOUS MATERIALS

NT-NU 24-HOUR SPILL REPORT LINE

TEL: (867) 920-8130

FAX: (867) 873-6924

EMAIL: spills@gov.nt.ca

REPORT LINE USE ONLY

A	REPORT DATE: MONTH – DAY – YEAR		REPORT TIME		<input type="checkbox"/> ORIGINAL SPILL REPORT, OR <input type="checkbox"/> UPDATE # _____ TO THE ORIGINAL SPILL REPORT	<div style="border: 2px solid black; padding: 5px;">           REPORT NUMBER            _____         </div>
	B		OCCURRENCE DATE: MONTH – DAY – YEAR			
C	LAND USE PERMIT NUMBER (IF APPLICABLE)			WATER LICENCE NUMBER (IF APPLICABLE)		
D	GEOGRAPHIC PLACE NAME OR DISTANCE AND DIRECTION FROM NAMED LOCATION				REGION <input type="checkbox"/> NWT <input type="checkbox"/> NUNAVUT <input type="checkbox"/> ADJACENT JURISDICTION OR OCEAN	
E	LATITUDE			LONGITUDE		
	DEGREES	MINUTES	SECONDS	DEGREES	MINUTES	SECONDS
F	RESPONSIBLE PARTY OR VESSEL NAME		RESPONSIBLE PARTY ADDRESS OR OFFICE LOCATION			
G	ANY CONTRACTOR INVOLVED		CONTRACTOR ADDRESS OR OFFICE LOCATION			
H	PRODUCT SPILLED		QUANTITY IN LITRES, KILOGRAMS OR CUBIC METRES		U.N. NUMBER	
	SECOND PRODUCT SPILLED (IF APPLICABLE)		QUANTITY IN LITRES, KILOGRAMS OR CUBIC METRES		U.N. NUMBER	
I	SPILL SOURCE		SPILL CAUSE		AREA OF CONTAMINATION IN SQUARE METRES	
J	FACTORS AFFECTING SPILL OR RECOVERY		DESCRIBE ANY ASSISTANCE REQUIRED		HAZARDS TO PERSONS, PROPERTY OR ENVIRONMENT	
K	ADDITIONAL INFORMATION, COMMENTS, ACTIONS PROPOSED OR TAKEN TO CONTAIN, RECOVER OR DISPOSE OF SPILLED PRODUCT AND CONTAMINATED MATERIALS					
L	REPORTED TO SPILL LINE BY		POSITION	EMPLOYER	LOCATION CALLING FROM	TELEPHONE
	M		ANY ALTERNATE CONTACT	POSITION	EMPLOYER	ALTERNATE CONTACT LOCATION
<b>REPORT LINE USE ONLY</b>						
N	RECEIVED AT SPILL LINE BY		POSITION	EMPLOYER	LOCATION CALLED	REPORT LINE NUMBER
			STATION OPERATOR		YELLOWKNIFE, NT	(867) 920-8130
LEAD AGENCY <input type="checkbox"/> EC <input type="checkbox"/> CCG <input type="checkbox"/> GNWT <input type="checkbox"/> GN <input type="checkbox"/> ILA <input type="checkbox"/> INAC <input type="checkbox"/> NEB <input type="checkbox"/> TC				SIGNIFICANCE <input type="checkbox"/> MINOR <input type="checkbox"/> MAJOR <input type="checkbox"/> UNKNOWN		FILE STATUS <input type="checkbox"/> OPEN <input type="checkbox"/> CLOSED
AGENCY		CONTACT NAME		CONTACT TIME		REMARKS
LEAD AGENCY						
FIRST SUPPORT AGENCY						
SECOND SUPPORT AGENCY						
THIRD SUPPORT AGENCY						



## Instructions for Completing the NT-NU Spill Report Form

Spills of hazardous substances can be reported by calling the NT-NU Spill Report Line at (867) 920-8130. Collect calls are accepted. As an alternative, the Spill Report form can be filled out and e-mailed as an attachment to spills@gov.nt.ca. Receipt of e-mail transmissions should be verified with a follow-up telephone call to the Spill Line. Completed forms can also be faxed to the Spill Line at (867) 873-6924.

<b>A. Report Date/Time</b>	The actual date and time that the spill was reported to the spill line. If the spill is phoned in, the Spill Line will fill this out. <b>Please do not fill in the Report Number:</b> the spill line will assign a number after the spill is reported.
<b>B. Occurrence Date/Time</b>	Indicate, to the best of your knowledge, the exact date and time that the spill occurred. Not to be confused with the report date and time (see above).
<b>C. Land Use Permit Number/ Water Licence Number</b>	This needs to be filled in only if the activity has been licensed by the Nunavut Water Board or if a Land Use Permit has been issued. Applies primarily to mines and mineral exploration sites.
<b>D. Geographic Place Name</b>	In most cases, this will be the name of the community where the spill occurred. For remote locations, identify the most prominent geographic feature, such as a lake or mountain or the distance and direction from the nearest community.
<b>E. Geographic Coordinates</b>	This needs to be filled out if the spill occurred outside of an established community such as at a mine site. The location should be stated in degrees, minutes and seconds of Latitude and Longitude.
<b>F. Responsible Party or Vessel Name</b>	Identify the person or party who owned or was in control of the substance at the time it was spilled. In the case of a spill from a ship or vessel, include the name of the ship or vessel. Include full address, telephone number and e-mail. Use box K if there is insufficient space. <b>Note that the owner of the spilled substance is ultimately responsible for any spills of that substance, regardless of who may have actually caused the spill.</b>
<b>G. Contractor involved?</b>	Were there any other parties or contractors involved (e.g. a construction company who is working on behalf of the owner of the spilled substance and who may have contributed to, or directly caused, the spill and is responding to the spill)?
<b>H. Product Spilled</b>	Identify the product spilled. Most commonly this is gasoline, diesel fuel or sewage. Use the chemical name of the substance and, where possible, identify the product using the four digit UN number (e.g. UN1203 for gasoline; UN1202 for diesel fuel; UN1863 for Jet A & B). Avoid trade names.
<b>I. Spill Source</b>	Identify the source of the spill (e.g. truck, ship, home heating fuel tank) and the cause (e.g. fuel tank overflow, leaking tank, ship ran aground, traffic accident, vandalism, storm). Provide an estimate of the extent of the contaminated area (e.g. 10 m <sup>2</sup> ).
<b>J. Factors Affecting Spill</b>	Identify any factors which might make it difficult to clean up the spill (e.g. rough terrain, bad weather, remote location, lack of equipment). Do you require advice and assistance with the cleanup? Identify any hazards to persons, property or environment (e.g. a gasoline spill beside a daycare centre would pose a safety hazard to children). Use box K if there is insufficient space.
<b>K. Additional Information</b>	Provide any additional pertinent details about the spill. State what action is being taken to clean up the spill, dispose of spilled material or notify affected parties. Attach additional sheets to the spill report if necessary. Number the pages in the same format found in the lower right hand corner of the spill form (e.g. Page 1 of 2). <b>Number the pages to ensure that recipients can be certain they received all pertinent documents.</b> If only the Spill Report form was filled out, number the form as "Page 1 of 1".
<b>L. Reported to Spill Line by</b>	Include your full name, employer, contact number and the location from which you are reporting the spill. Use box K if there is insufficient space.
<b>M. Alternate Contact</b>	Identify any alternate contacts. This information assists regulatory agencies to obtain additional information if they cannot reach the individual who reported the spill.
<b>N. Report Line Use Only</b>	<b>Leave Blank. This box is for Spill Line use only.</b>



